

Dual-Band High Precision GNSS Antenna Module **GEM1301**

Datasheet V1.0

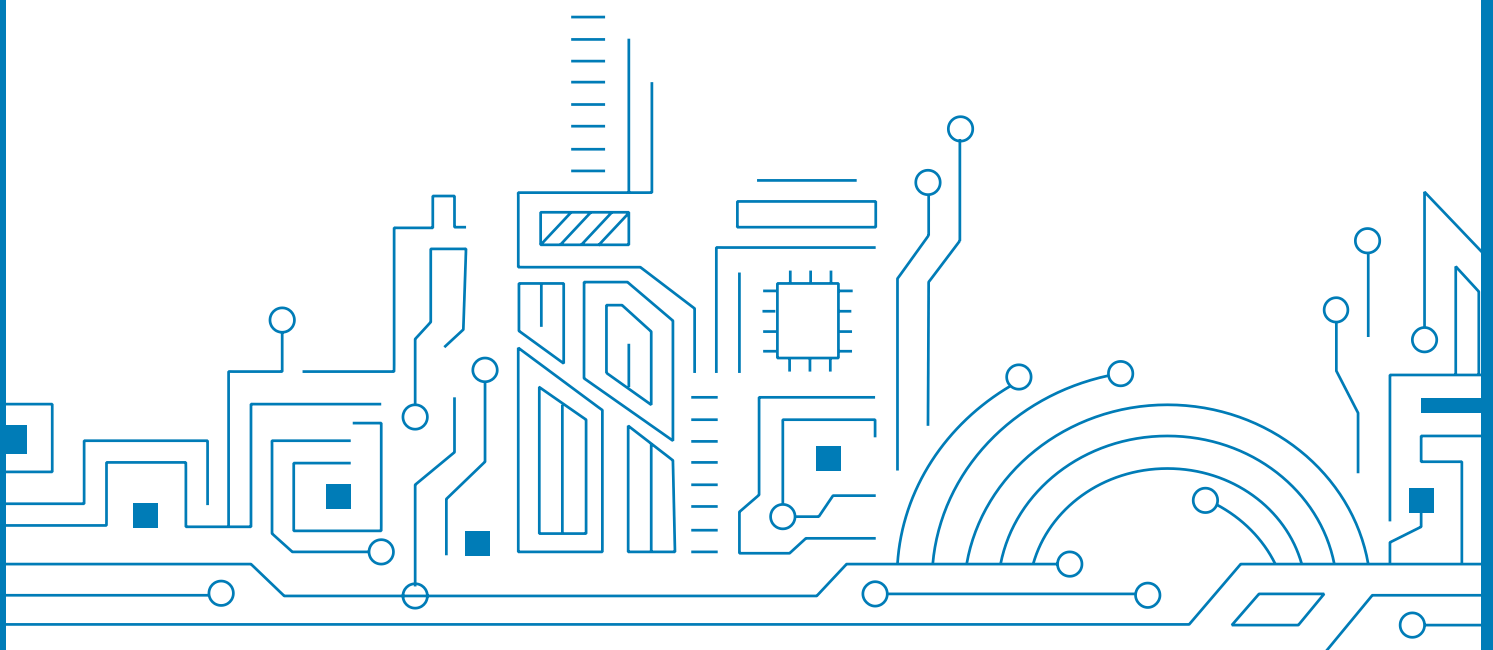

Notice, Statement and Copyright

ALLYSTAR Technology offers this document as a service to its customers, to support application and engineering efforts that use the products designed by ALLYSTAR Technology. Products and specifications discussed herein are for reference purposes only. Performance characteristics listed in this document do not constitute a warranty or guarantee of product performance.

ALLYSTAR Technology assumes no liability or responsibility for any claims or damages arising out of the use of this document, or from the use of integrated circuits based on this document, including, but not limited to claims or damages based on infringement of patents, copyrights or other intellectual property rights.

This document contains proprietary technical information which is the property of ALLYSTAR Technology, copying of this document and giving it to others and using or communication of the contents thereof, are forbidden without express authority. Offenders are liable to the payment of damages. ALLYSTAR Technology reserves the right to make changes in its products, specifications and other information at any time without notice.

For more recent documents, please visit www.allystar.com.

Copyright © Allystar Technology (Shenzhen) Co., Ltd. 2022. All rights reserved.

About the document

■ Basic info

Document applies to	GEM1301
Document type	Datasheet
Revision and date	V1.0/2022-07
Product status	Mass production

■ Product status description

In development	Objective specification. Revision may be released in later status.
Engineering sample	Product specifications tested on early. Revision may be released in later status.
Preliminary	Product specifications come from small production. Revision may be released in later status.
Mass production	Final product specification to mass market.

TABLE OF CONTENTS

1	SYSTEM OVERVIEW	6
1.1	Overview	6
1.2	Features	6
1.3	Product photo	6
1.4	Block diagram	7
1.5	Specifications	7
2	PIN DESCRIPTION	9
2.1	Pin assignment	9
2.2	Detailed pin description.....	9
3	ELECTRICAL CHARACTERISTICS	10
3.1	Absolute maximum rating	10
3.2	IO Characteristics	10
3.2.1	RESET and BOOT	10
3.2.2	Others	10
3.3	DC characteristics	11
3.3.1	Operating conditions.....	11
3.3.2	Power consumption	11
4	HARDWARE DESCRIPTION	12
4.1	Power	12
4.2	Power on/off Sequence.....	12
4.2.1	Initial system power on.....	12
4.3	Reset and mode control	12
5	MECHANICAL SPECIFICATION.....	14
6	DEFAULT MESSAGE.....	15
7	PRODUCT PACKAGING AND HANDLING.....	16
7.1	Packaging	16
7.1.1	Shipment.....	17
7.1.2	Storage.....	17
7.1.3	Moisture sensitivity level	17
8	LABELING AND ORDERING INFORMATION.....	18
8.1	Labeling.....	18
8.2	Ordering info	18
9	RELATED DOCUMENTS.....	18

10 REVISION HISTORY 19

List of Tables

Table 1 GEM1301	6
Table 2 Specifications	7
Table 3 Detailed pin description	9
Table 4 Absolute rating.....	10
Table 5 RESET and BOOT	10
Table 6 PPS	10
Table 7 UART	10
Table 8 Operating conditions	11
Table 9 Power consumption	11
Table 10 Dimensions	14
Table 11 Default message.....	15
Table 12 GEM1301 labeling content.....	18
Table13 Ordering info	18

List of Figures

Figure 1 GEM1301	6
Figure 2 Block diagram.....	7
Figure 3 Pin assignment.....	9
Figure 4 Initial system power on sequence	12
Figure 5 Mode switch	13
Figure 6 Minimum reset time	13
Figure 7 Dimensions.....	14
Figure 8 Packaging	16
Figure 9 Laser carving on the shielding case of GEM1301	18

1 SYSTEM OVERVIEW

1.1 Overview

GEM1301 is a high-performance dual-band high precision GNSS positioning module with antenna built-in, which is based on the state of the art CYNOSURE III GNSS SoC chip. It supports BDS-3 signals, along with global civil navigation systems, including GPS, BDS, GLONASS, Galileo, QZSS, and SBAS.

1.2 Features

- Supports GPS, BDS, GLONASS, Galileo, QZSS, and SBAS
- Integrated Real Time Kinematics (RTK)
- State-of-the-art low power consumption design
- Supports multi-band multi-system high precision raw data output, easy for 3rd party integration
- The best cost-effective high precision GNSS positioning solution integrated with antenna

Table 1 GEM1301

Product model	GNSS								Feature						Interface			Accuracy				
	Band (S/D/T)	GPS	BDS	GLONASS	Galileo	NavIC	QZSS	SBAS	Built-in LNA	Programmable (Flash)	Data logging	D-GNSS	Raw data	RTK	Oscillator	Built-in inductor	UART	USB	SPI	Meter	Sub-meter	Centimeter
GEM1301	D	●	●	Δ	●		●	●	●		●	●	●	●	T		●			Meter	Sub-meter	●

T = TCXO

Δ = Supported upon special firmware

1.3 Product photo

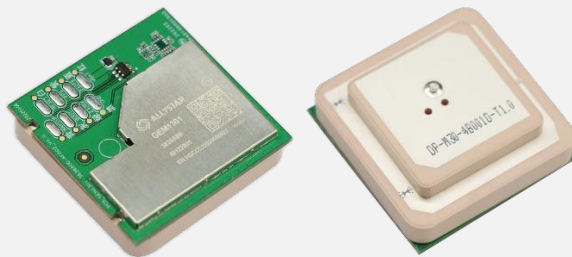

Figure 1 GEM1301

1.4 Block diagram

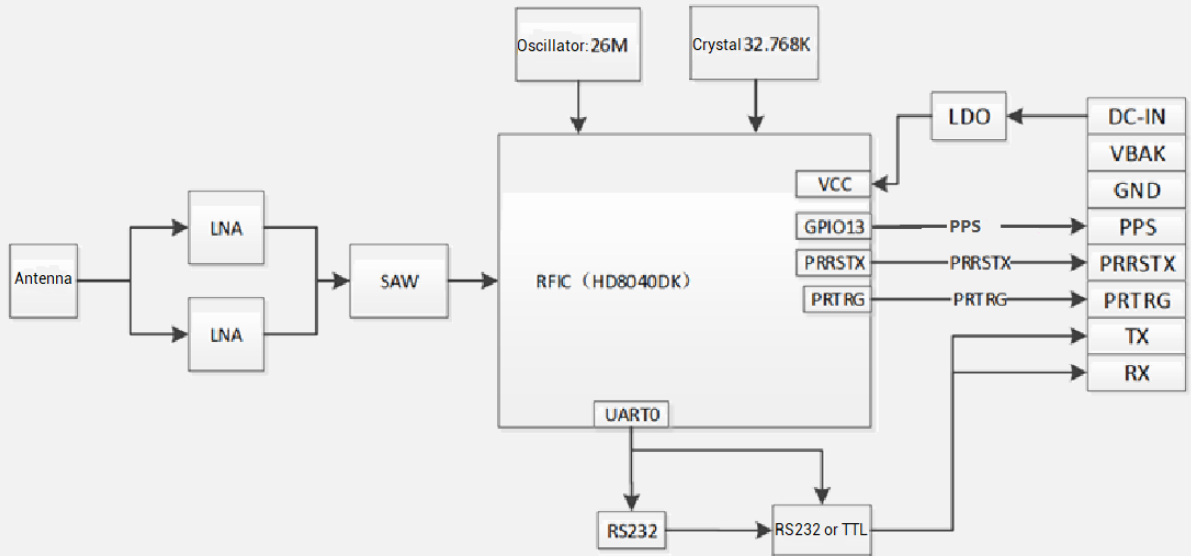

Figure 2 Block diagram

1.5 Specifications

Table 2 Specifications

Parameter	Specification	
GNSS tracking channels	40	
GNSS reception	GPS/QZSS: L1C/A, L5	
	BDS: B1I, B2a	
	Galileo: E1, E5a	
	GLONASS: G1	
	SBAS: L1	
Update rate	PVT	5 Hz
	RTK	1 Hz
Position accuracy ^[1]	GNSS	1.0m CEP
	D-GNSS	<1.0m CEP
	RTK	1.0 cm + 1 ppm (H) 3.0 cm + 1 ppm (V)
Velocity & Time accuracy	GNSS	0.1 m/s CEP
	1PPS	20 ns
Time To First Fix (TTFF)	Hot start	<2s
	Cold start	<30s
	RTK convergence	<10s
Sensitivity	Cold start	-148 dBm

	Hot start	-155 dBm
	Reacquisition	-158 dBm
	Tracking	-162 dBm
Operating limit	Velocity	515 m/s
	Altitude	18,000m
Interfaces	RS232/TTL ^[1]	1
Protocol	NMEA 0183 Protocol Ver. 4.11(Default)/4.10 Cynosure GNSS Receiver Protocol RTCM 3.0/3.2	
Operating condition	Main voltage	3.3-12 V
	I/O voltage	3.0-3.6 V
	Backup voltage	1.8-3.6 V
Power consumption	Acquisition	55 mA @ 3.3V
	Tracking	51 mA @ 3.3V
	Standby	12 uA
ESD	Contact discharge: ±8 KV Air discharge: ±12 KV	
Operating temperature	-40°C to +85°C	
Storage temperature	-40°C to +85°C	
Package	38*38*13.2 mm	
Certification	RoHS 2.0, REACH	

* [1] GEM1301-3838A01 supports RS232 level, and GEM1301-3838A02 supports TTL level.

2 PIN DESCRIPTION

2.1 Pin assignment

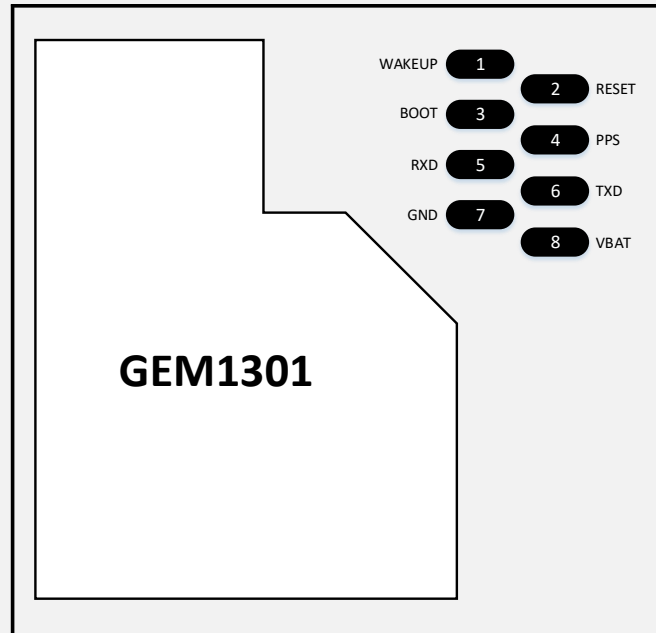

Figure 3 Pin assignment

2.2 Detailed pin description

Table 3 Detailed pin description

Function	Symbol	No.	I/O	Description
Power	VBAT	8	Power	Main voltage supply, 3.3-12 V DC.
	GND	7	VSS	Ground
	WAKEUP	1	Power	Backup voltage supply, 1.8-3.6 V.
UART	RXD	5	I	UART serial data input.
	TXD	6	O	UART serial data output.
System	BOOT	3	I	Mode selection
	RESET	2	I	External reset signal input, high active.
	PPS	4	O	Time pulse output (PPS)

3 ELECTRICAL CHARACTERISTICS

3.1 Absolute maximum rating

Table 4 Absolute rating

Symbol	Parameter	Min.	Max.	Unit
VBAT	Main power supply	-0.3	18	V
WAKEUP	Backup supply	-0.5	3.6	V
T _{storage}	Storage temperature	-40	85	°C

3.2 IO Characteristics

3.2.1 RESET and BOOT

Table 5 RESET and BOOT

Symbol	Parameter	Condition	Min.	Typ.	Max.	Unit
I _{IZ}	Input leakage current	--	--	--	+/-1	uA
V _{IH}	Input high voltage	--	3.3*0.7	--	3.3	V
V _{IL}	Input low voltage	--	0	--	0.3	V
R _{PU}	Pull-up resistance	--	30	--	80	kOhm

3.2.2 Others

Table 6 PPS

Symbol	Parameter	Condition	Min.	Typ.	Max.	Unit
I _{OZ}	Output leakage current	--	--	2	--	mA
V _{OH}	Output high voltage	--	3.3*0.7	--	3.3	V
V _{OL}	Output low voltage	--	0	--	0.4	V
R _{PU}	Pull-up resistance	--	30	--	80	kOhm

Table 7 UART

Symbol	Parameter	Condition	Min.	Typ.	Max.	Unit
V _{IH}	Input high voltage	--	-15	--	-3	V
V _{IL}	Input low voltage	--	3	--	15	V
V _{OH}	Output high voltage	I _{OH} = 11.9 mA, VBAT = 3.3V	-6	--	-5	V
V _{OL}	Output low voltage	I _{OH} = 7.9 mA, VBAT = 3.3V	5	--	6	V

3.3 DC characteristics

3.3.1 Operating conditions

Table 8 Operating conditions

Symbol	Parameter	Min.	Typ.	Max.	Unit
V _{BAT}	Main power supply	3.0	3.3	12	V
WAKEUP	Backup supply	1.8	3.3	3.6	V
I _{CCmax}	Maximum operating current @ V _{BAT}	--	--	200	mA
T _{env}	Operating temperature	-40	--	85	°C
T _{storage}	Storage temperature	-40	--	85	°C

3.3.2 Power consumption

Table 9 Power consumption

Symbol	Parameter	Measure pin	Typ.	Unit
I _{CCR_{X1}}	Average tracking current	V _{BAT}	51	mA
I _{CCDBM}	Standby	WAKEUP	12	uA

4 HARDWARE DESCRIPTION

4.1 Power

GEM1301 positioning module has two power supply pins: VBAT and WAKEUP. The main power is supplied through the VBAT pin, and the backup power is supplied through the WAKEUP pin. In order to ensure the positioning performance, please control the ripple of the module power supply. It is recommended to use the LDO above 200 mA.

If the power for VBAT pin is off, the real-time clock (RTC) and battery backed RAM (BBR) will be supplied through the WAKEUP pin. Thus, orbit information and time can be maintained and will allow a Hot or Warm start. If no backup battery is connected, the module will perform a cold start at every power-up if no aiding data are sent to the receiver.

Note: If no backup supply is available, leave the WAKEUP pin floating.

4.2 Power on/off Sequence

The module has two independent power domains (backup and main domain). In data backup mode, main power supply can be shut down for further power reduction for ultra-low power application.

4.2.1 Initial system power on

Initial system power on sequence is illustrated Figure 4.

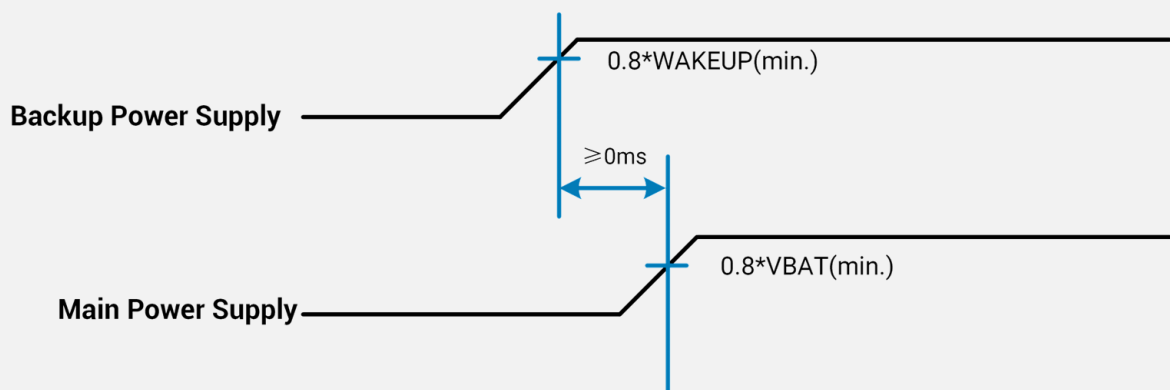

Figure 4 Initial system power on sequence

4.3 Reset and mode control

The operation mode of GNSS module is controlled by RESET and BOOT pin. BOOT pin cannot work alone when the module works normally. RESET pin can reset the system. Please leave RESET and BOOT pins floating if there is no system upgrading or reset demands.

Users may switch the mode through BOOT and RESET pin. Please see details in Figure 5.

- Instructions in Figure 5 enables users to enter **BOOT Mode**. Users can download the firmware to upgrade in **BOOT Mode** through serial port. The system cannot reset automatically after

firmware upgrading, which needs to enter **User Operation Mode** through RESET pin.

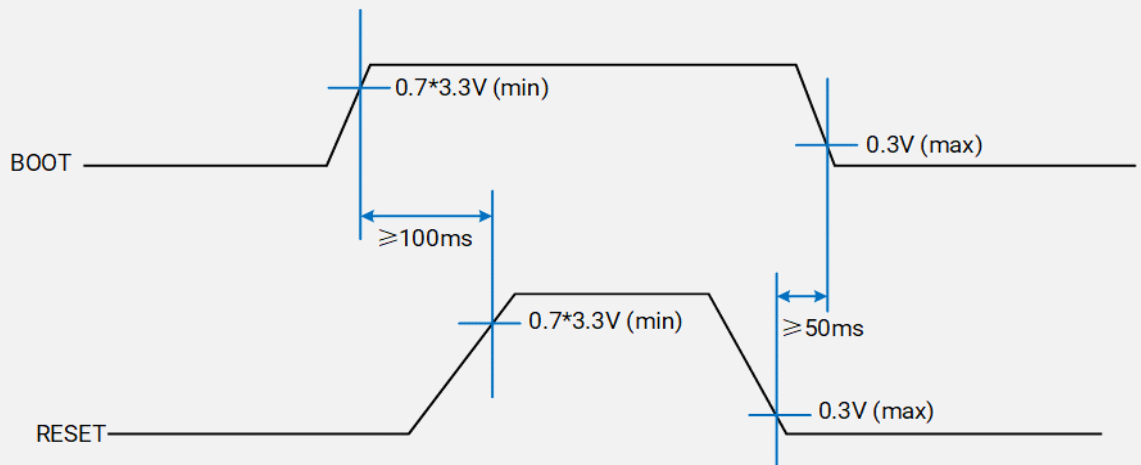

Figure 5 Mode switch

Parameter	Symbol	Pin	Condition	Min.	Typ.	Max.	Unit
Reset input time	t_{RSTL}	RESET	Normal supply with stable oscillator	100	--	--	mS

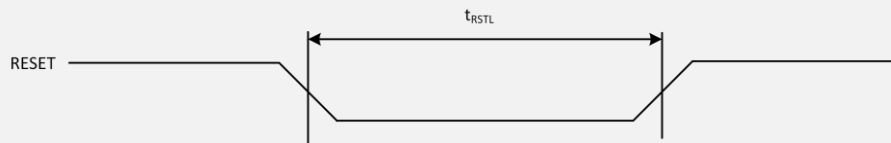

Figure 6 Minimum reset time

5 MECHANICAL SPECIFICATION

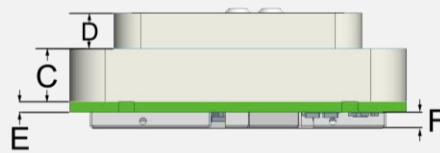
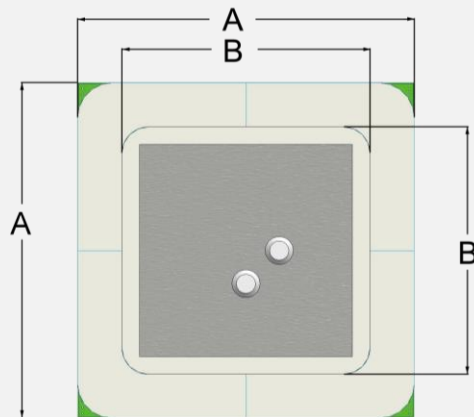

Figure 7 Dimensions

Table 10 Dimensions

Symbol	Min. (mm)	Typ. (mm)	Max. (mm)
A	37.8	38.0	38.2
B	27.8	28.0	28.2
C	5.9	6.0	6.1
D	3.9	4.0	4.1
E	1.08	1.2	1.32
F	1.9	2.0	2.1

6 DEFAULT MESSAGE

Table 11 Default message

Interface	Settings
UART output	115200 baud, 1 start bit, 8 data bits, no parity bit, 1 stop bit Configured to transmit both NMEA and HD Binary protocols, but only the following NMEA messages have been activated at start-up: RMC, GGA, GSA, GSV, GST, SVD.
UART input	115200 baud, 1 start bit, 8 data bits, no parity bit, 1 stop bit Automatically accepts the following protocols without explicit configuration: HD binary sentence, NMEA, RTCM
PPS	1 pulse per second, synchronized at rising edge, pulse length 100 ms.

* Refer to *GNSS_Protocol_Specification* for information about other settings.

7 PRODUCT PACKAGING AND HANDLING

7.1 Packaging

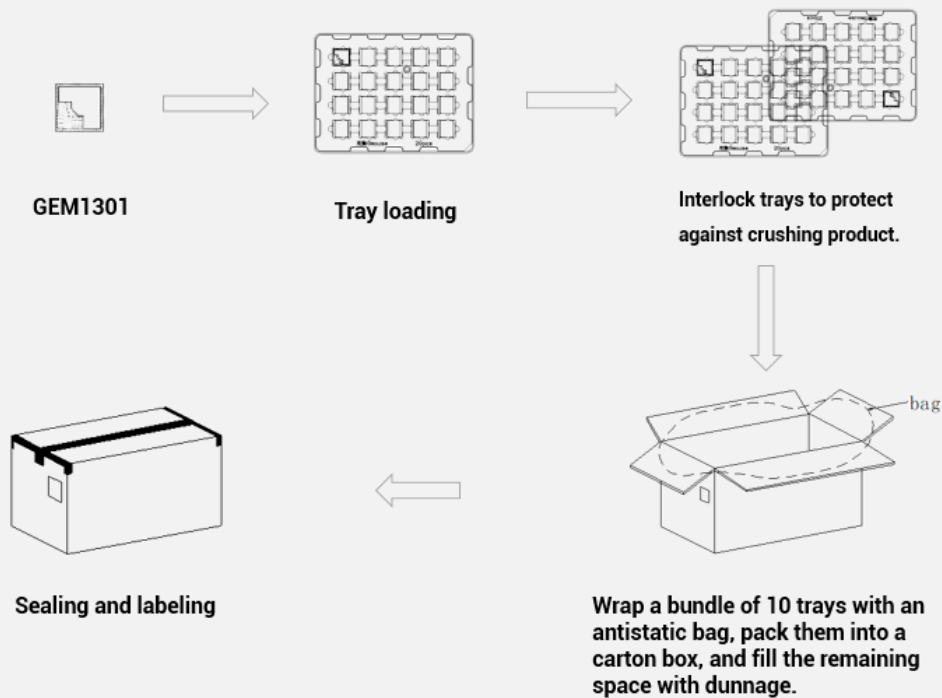

Figure 8 Packaging

Packing instructions

1. Modules are loaded on the antistatic tray. Ten trays are wrapped up with one antistatic bag and packed with double wall corrugated carton box.
2. Dimensions of carton box: 380*290*220 mm (L*W*H)
3. Each carton contains 10 antistatic trays loading 20 pcs modules each, totally 200 pcs.
4. Net weight: $50g \times 200 = 10 \times (1 \pm 10\%)$ kg
5. Gross weight: $10 + 0.11 \times 18 + 0.5 = 12.48 \times (1 \pm 10\%)$ kg
6. The above quantities and weights are for packages shown in Figure 8 only. There might be slight differences upon delivery. Please prevail in kind.

7.1.1 Shipment

Due to their volume and ESD character, modules are loaded in antistatic trays wrapped up with sealed antistatic bags, and shipped by shipping cartons.

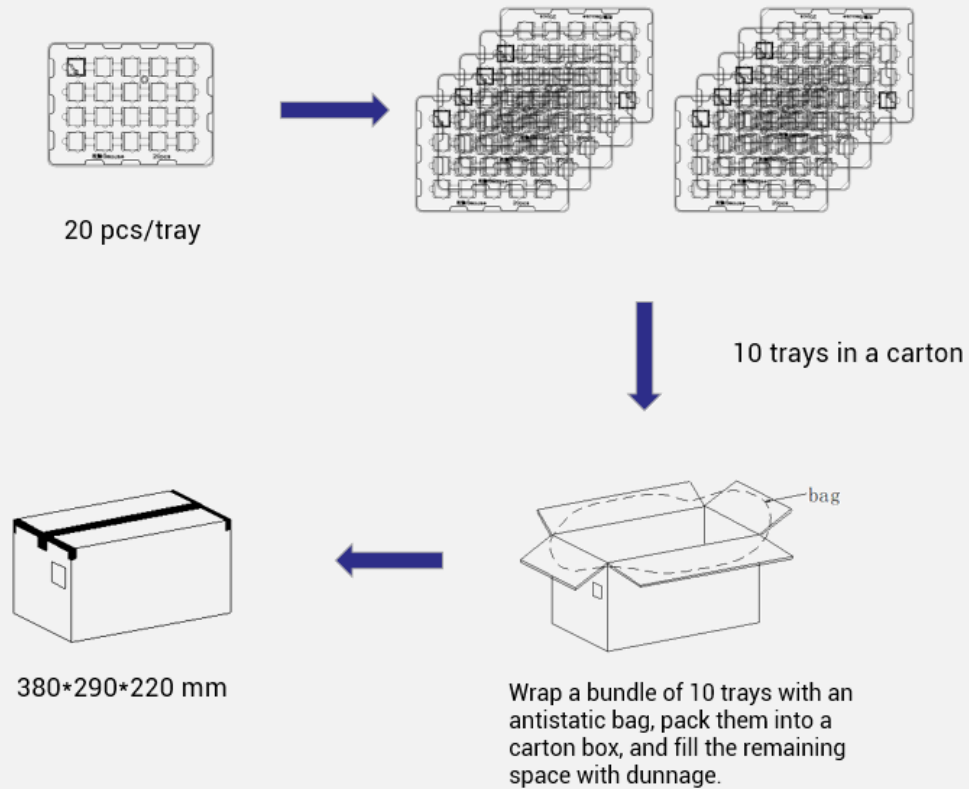

7.1.2 Storage

In order to prevent moisture intake and protect against electrostatic discharge, it is advised to store products in the environment of 30%-70% RH at 10°C to 28°C.

7.1.3 Moisture sensitivity level

The Moisture Sensitivity Level (MSL) of the GNSS module is MSL3.

8 LABELING AND ORDERING INFORMATION

Labeling and ordering information help customers get more about Allystar products.

8.1 Labeling



Figure 9 Laser carving on the shielding case of GEM1301

Table 12 GEM1301 labeling content

Symbol	Explanation
GEM1301	Product model, for marketing promotion.
3838A01	Product type info. 3838 represents the product size, and A01 means product type.
401xxyyy	The product control code. 401 is a fixed number, xx is year, and yyy is batch number.
SN:HGCAA21480000343	Serial number
QR code	Contains product control code and serial number

8.2 Ordering info

Table13 Ordering info

Ordering No.	Product information
GEM1301-3838A01	Dual-band high precision GNSS antenna module, 38*38 mm, UART RS232 level, 200 pcs/carton.
GEM1301-3838A02	Dual-band high precision GNSS antenna module, 38*38 mm, UART TTL level, 200 pcs/carton.

9 RELATED DOCUMENTS

- [1] Satrack User Manual
- [2] Allystar Common Commands
- [3] GNSS_Protocol_Specification

10 REVISION HISTORY

Revision	Date	Revised by	Status/Comments
V1.0	2022-07	Cao Min	Initial release.



www.allystar.com



info.gnss@allystar.com



Headquarters

Allystar Technology (Shenzhen) Co., Ltd.

Address: 201-2, 2F, Tower F, Xinghe World, No.1, Yabao Road, LongGang District, Shenzhen City, Guangdong Province, China.

Calgary Office

Allystar Technology (Canada) Ltd.

Address: Unit 288, 3553 31 Street NW Calgary, Alberta, Canada T2L 2K7

